

# The BEAST Septage Receiving System

With Hauler Station - Access Panel - Flo-Logic® Software

VFA-DM-HS

SAVI

Fully integrated, secure, 24/7 operation and the next generation of septage screening.



## A System Designed Specifically for Septage Pre-treatment

This fully integrated system is made up of three components: The BEAST in tank septage screen, the Hauler Station with Access Panel and the Flo-Logic Software.

The BEAST's function is to screen the heavy debris from the septage; and convey, wash, and dewater that debris prior to discharge. The BEAST does not require a rock trap or other high maintenance add-ons such as grinders.

Both the screen and the tank have been designed to eliminate the problems that plague other equipment currently available for septage receiving applications. The result is fast truck unloading times and high capture efficiency.

The Flo-Logic® software is the management system used in conjunction with the BEAST and the Hauler Station that provides security, data logging and reporting/invoicing capabilities. Permitted haulers can have secure access, 24/7 by using simple login procedures and a key card. Data on flow, volume and types of loads can be collected, monitored and used to generate invoices to the haulers. Flo-Logic software is flexible and can be modified to meet the needs of any facility receiving septage.



## The Hauler Station

- Electrically actuated inlet valve
- Magnetic flow meter
- Hauler access panel
- Flo-Logic® software

# Flo-Logic® Software

## Security

- Provides 24/7 access to permitted haulers.

## Data Logging

- Automatically collects data regarding trucks and septage loads.

## Reporting

- Provides data sorting capabilities, report generating and billing information.
- Simple network connections.



Key card activated.

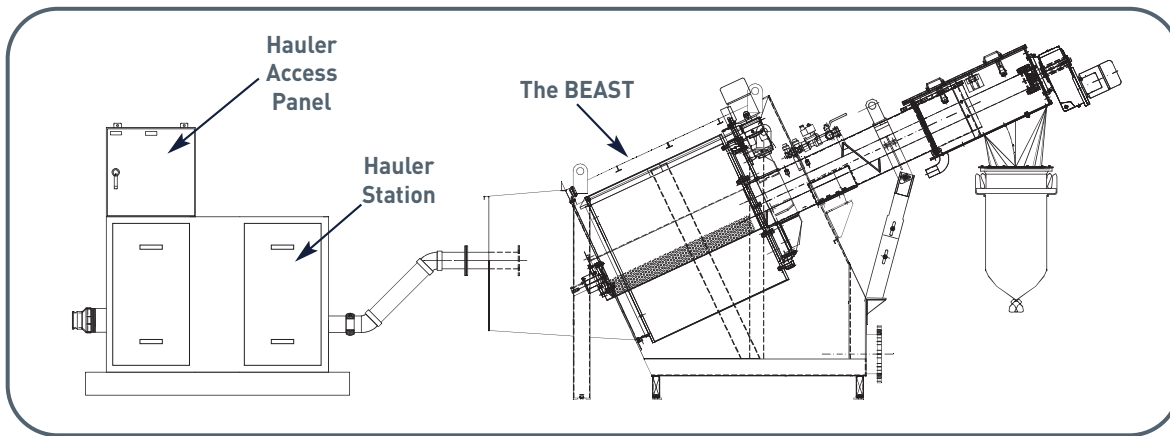

Kershaw County South Carolina BEAST Septage Receiving Station