

FLO-Beast Liquid Waste Receiving System

FWRS

With Hauler Station - Access Panel - Flo-Logic™ Software

Fully integrated, secure, 24/7 operation and the next generation of septage screening.



A System Designed Specifically for Septage Pre-treatment

This system is made up of three different components. The Braun, the Integrator and the Brains.

The Flo-Beast SeptageStation DM is the Braun of this system. It screens the heavy solids from the septage and conveys, washes, and dewater those solids prior to discharge. The Beast does not require a rock trap or other high maintenance add-ons, such as grinders.

Both the screen and tank have been designed to eliminate the problems that plague other equipment currently available for septage applications. The result is fast truck unloading times and high capture efficiency.

Between the Beast and the Brains, is the Integrator hauler station. The hauler station controls and monitors the flow of septage between the truck and the screen.

The hauler access panel is connected to the hauler station and contains the Brains of the system - the Flo-Logic™ software.



The Hauler Station

- Electrically actuated inlet valve
- Magnetic flow meter
- Hauler access panel
- Flo-Logic™ software

The Brains - Flo-Logic™ Software

Security

- Provides 24/7 access to permitted haulers.

Data Logging

- Automatically collects data regarding trucks and septage loads.

Reporting

- Provides data sorting capabilities, report generating and billing information.
- Simple network connections.
- Can be WiFi enabled for data transfer to remote locations.



Key card activated.

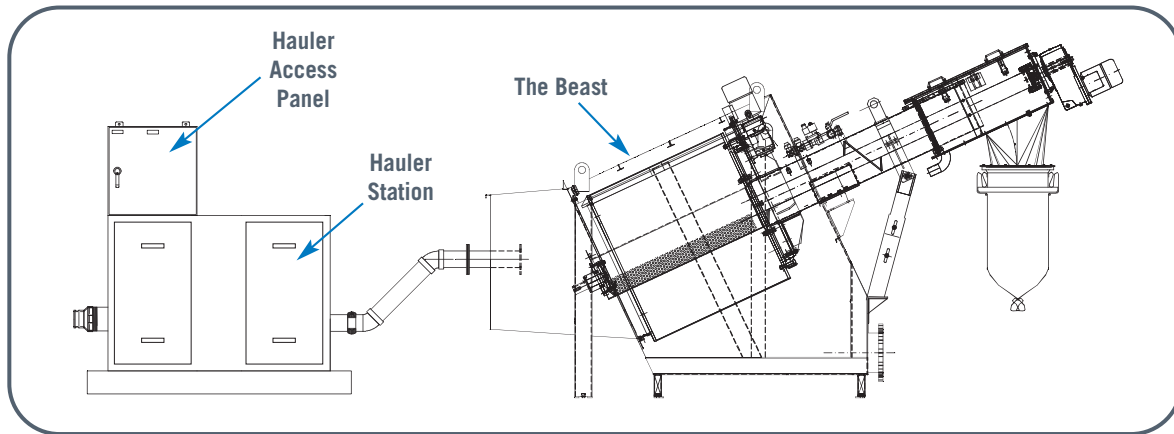

FLO-Products

Simply Superior Design

Enviro-Care Company of Rockford Illinois was founded in 1972 and is a privately-held headworks company supplying screens and solids/grit management equipment for wastewater treatment. Enviro-Care is the North American partner of SAVI S.r.l. of Roncoferraro

Screens

Flo-Drum Rotating Drum Screen for Wastewater and MBR Pre-screening

Flo-Drum DM Dual Drive, Heavy Solids Screen

Flo-Sieve Shaftless Spiral Screening, Washing, Conveying, Dewatering System

Flo-MultiRake Coarse and Fine Bar Screens

Flo-MultiRake Perforated Media Screen

Flo-PerfBelt Moving Media Belt Screen

Flo-Screen Reciprocating Rake Bar Screen

Flo-RotoDrum Internally-fed Rotating Drum Screen

Flo-DrumSieve Externally-fed Rotating Drum Screen

Italy and has the exclusive sales distribution and manufacturing license for SAVI products. SAVI was founded in 1978 and is a worldwide leader in wastewater treatment equipment with thousands of installations around the world.

Solids/Grit Management

Flo-WashPress Washer Compactor

Flo-Press Hydraulic Ram Press

Flo-SpiralPress Conveyor with Dewatering

Flo-GritWash Grit Classifier and Washer

Flo-GritOut Grit Classifier

Flo-Spiral Shaftless Spiral Conveyor

Systems

Flo-Beast SeptageStation DM For Heavy Solids Screening

Flo-Beast Liquid Waste Receiving Station With Hauler Station - Access Panel - Flo-Logic™ Software



Enviro-Care is the exclusive licensee for SAVI S.R.L. technologies in North America.

5701 Industrial Avenue
Loves Park (Rockford) Illinois 61111 U.S.A.
P. 815.636.8306 • F: 815.636.8302

ecsales@Enviro-Care.com
www.Enviro-Care.com

© 2014 Enviro-Care
FWRS-0414
Revision: A