

SAVI® MultiRake

Perforated Plate Screen
GVS

SAVI

Another High Capture Screen from Enviro-Care®



SAVI® MultiRake Perf Vertical Screen.

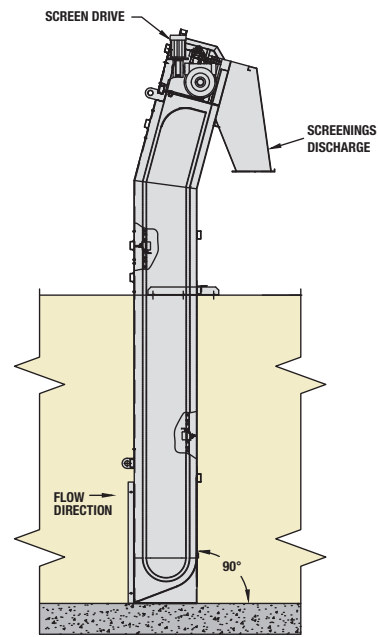

90° Design

In this unique MultiRake screen design, bars are replaced by stainless steel perforated plate to achieve higher debris capture. This screen can be mounted at 90° for deep narrow channels and pump stations. It is also available in tank for pumped flow. The low maintenance design makes it excellent for remote locations.

Depending on the height of the screen, a minimum of 2 - 6 cleaning mechanisms that consist of alternating wipers and brushes removes the debris from the upstream side of the perforated plate surface and carries it to discharge. The cleaning devices are attached to heavy duty roller chain. Chain segments are replaceable at the operating level without removing the screen from the channel.

The unit is equipped with lower chain return guides in order to maintain proper alignment and engagement of the cleaning mechanisms with the perforated panel. A mechanical scraper assembly removes the debris from the cleaning mechanisms and deposits this material into a discharge chute.



Fish Creek WI In Tank Unit Feeding a SPECO® Conveying Compactor.



It is projected and based on observed performance that this perforated plate MultiRake is capable of achieving a capture rate of 70% or greater depending on the type of debris being screened. Perforated plate is particularly good at removing wipes from the flow which also allows the screen to build a mat that attracts smaller material which further enhances capture.

Features

- 1 A combination of wipers and brushes remove solids and clean the perforated plate.
- 2 Cleaning mechanisms are bolted to the rake mechanism and designed for easy replacement.
- 3 Chain is replaceable at the operating level.
- 4 Lower, recessed chain guide maintains proper chain alignment and cleaning engagement.

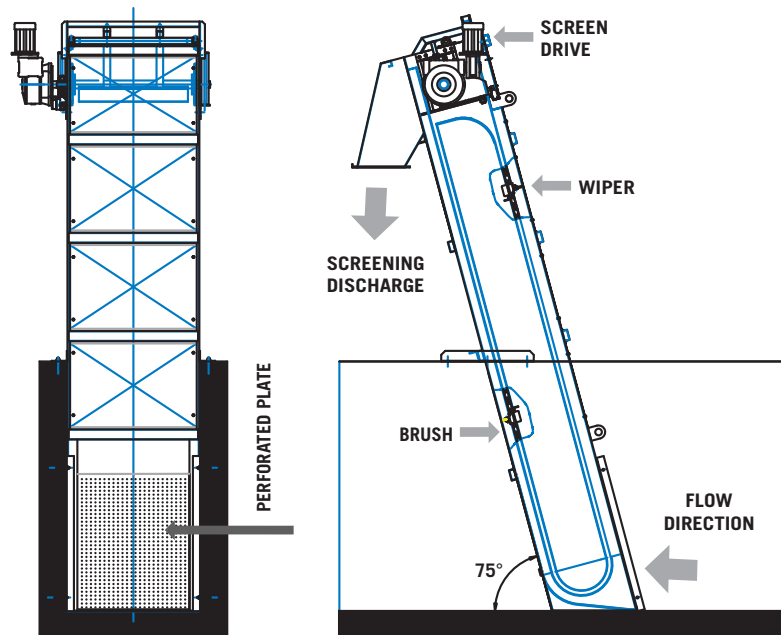

Specifications

Angle of inclination	75° and 90°
Screen opening	2 – 6 mm
Screen width	16" to 36"
Materials of construction	AISI 304 SST (316 optional)